

**Tektronix**<sup>®</sup>  
COMMITTED TO EXCELLENCE

**PLEASE CHECK FOR CHANGE INFORMATION  
AT THE REAR OF THIS MANUAL.**

**OPTION 03**

**P6021**

**CURRENT PROBE  
AND TERMINATION**

**INSTRUCTION MANUAL**

**Tektronix, Inc.  
P.O. Box 500  
Beaverton, Oregon 97077**

• 070-0947-00  
Product Group 60

Serial Number \_\_\_\_\_

First Printing MAR 1969  
Revised NOV 1985

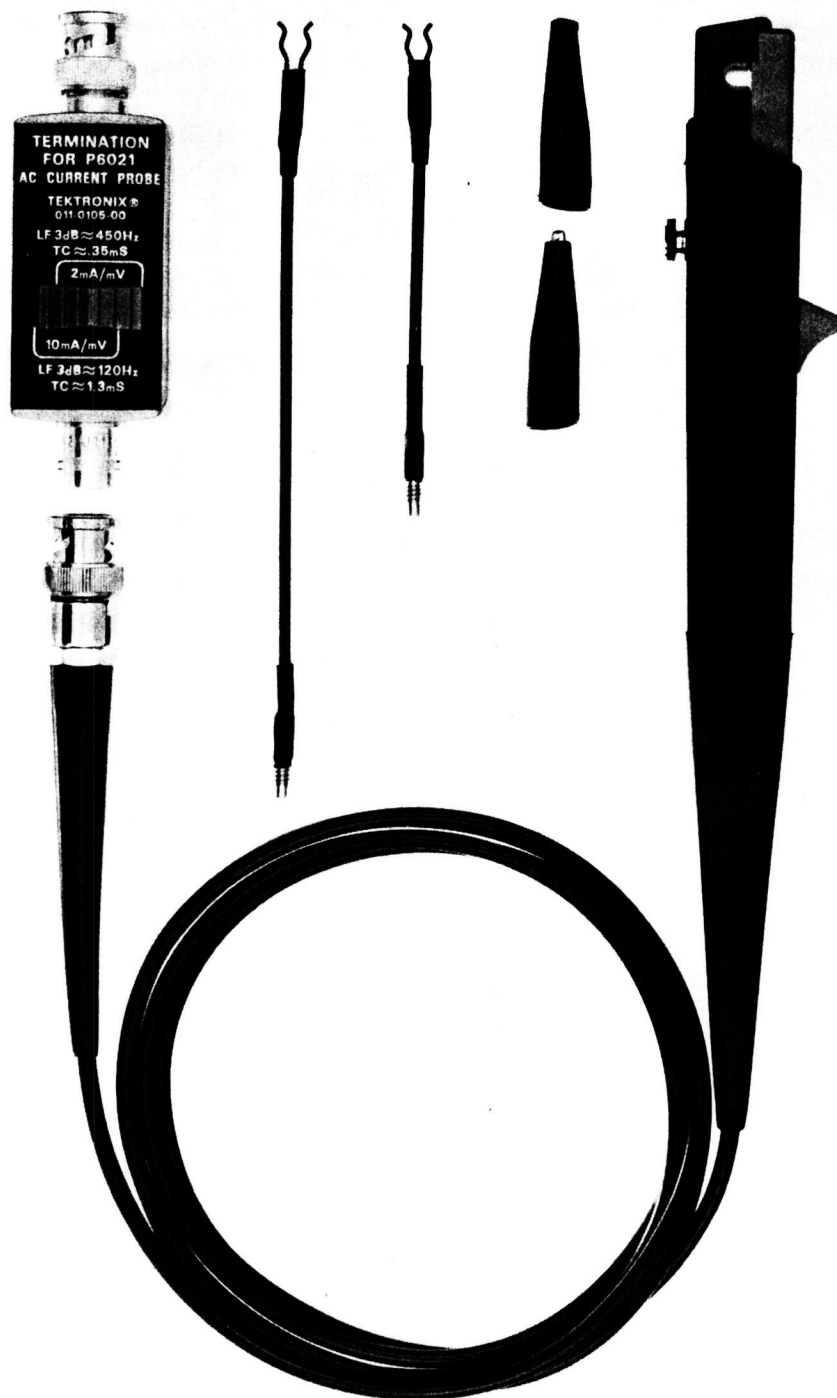

Fig. 1-1. P6021 Current Probe and Termination.

# SECTION 1

## SPECIFICATION

### Introduction

The Tektronix P6021 5 foot and 9 foot Current Probes are designed to measure alternating current waveforms. These probes, used with current devices such as the Type 134 Current Probe Amplifier, 7A14 Current Probe Amplifier plug-in, or the P6021 Passive Termination, permit a current waveform to be viewed and measured on the oscilloscope. This instruction manual deals primarily with the P6021 Current Probe as used with the Termination. For information concerning use with the current probe amplifier, refer to the appropriate current probe amplifier instruction manual.

The specifications pertain to the P6021 Current Probe with Termination.

### ELECTRICAL CHARACTERISTICS

(For both 5 foot and 9 foot versions unless otherwise stated)

Characteristic	Performance
Step Response	
5 Foot Probe Aberrations (Probe and Termination only)	
2 mA/mV	+3%, -3% or less, total of 4% or less peak to peak within 50 nanoseconds of step; +1%, -1% or less, total of 2% or less peak to peak thereafter.
10 mA/mV	+3%, -3% or less, total of 4% or less peak to peak within 50 nanoseconds of step; +1%, -1% or less, total of 2% or less peak to peak thereafter.
9 Foot Probe Aberrations (Probe and Termination only)	
2 mA/mV and 10 mA/mV	+4%, -4% or less, not to exceed 5% peak to peak within 50 nanoseconds of step. +1%, -1% or less, total not to exceed 2% peak to peak thereafter.
Risetime (Probe and Termination only)	
2 mA/mV	4.5 nanoseconds or less
10 mA/mV	4 nanoseconds or less

### ELECTRICAL CHARACTERISTICS (cont)

Characteristic	Performance
Risetime (with 580 Series test oscilloscope)	
2 mA/mV	6.7 nanoseconds or less
10 mA/mV	6.5 nanoseconds or less
Tilt	
2 mA/mV	4% or less within ten microseconds of step
10 mA/mV	4% or less within 100 microseconds of step
Sensitivity	Two milliamperes or ten milliamperes for each millivolt at oscilloscope input, selected by slide switch.
Accuracy	Within $\pm 3\%$
Bandwidth (with 580 Series test oscilloscope)	
2 mA/mV	450 hertz or less to 52 megahertz or more
10 mA/mV	120 hertz or less to 54 megahertz or more
Maximum CW Current	15A peak to peak sinewave between 1.2 kHz and 5 MHz at 2 mA/mV; between 300 Hz and 5 MHz at 10 mA/mV.
Maximum Pulse Current	250 amperes peak, not to exceed 500 A- $\mu$ s or 5 amperes RMS. Ampere-second product in excess of 500 A- $\mu$ s reduces probe output to zero due to core saturation.
Maximum Voltage	600 volts (DC + peak AC)
Maximum DC Saturation	0.5 amperes
Delay Time	Approximately 9 nanoseconds (5 foot probe) or 15.8 nanoseconds (9 foot probe) with termination.
Insertion Impedance	0.03 $\Omega$ or less at 1 MHz, increasing to 1.0 $\Omega$ or less at 60 MHz.

## SECTION 2

# OPERATING INSTRUCTIONS

### General

The P6021 Current Probe, when used with a P6021 Termination and an oscilloscope, provides a means of measuring alternating current waveforms. To effectively use the P6021, the operation and capabilities of the probe should be known. This section gives first-time and general operating information and some basic applications for the probe.

### Installation

When the P6021 Current Probe is used with the Termination, an oscilloscope having a vertical amplifier input impedance of one megohm is required. The probe and termination contain adjustments to optimize performance, matching the input characteristics of the vertical amplifier. To use the probe, first connect the P6021 Termination to the vertical input of the oscilloscope. Then connect the P6021 Current Probe to the termination (see Fig. 2-1).

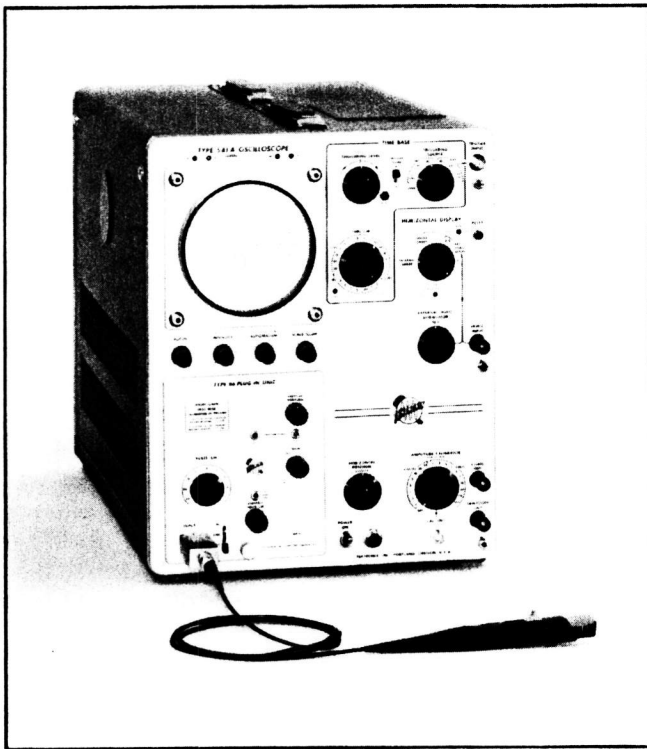

Fig. 2-1. The P6021 Current Probe and Termination connected to a test oscilloscope.

### Sensitivity Control

The P6021 Termination has a slide switch which changes the sensitivity of the probe and termination by a factor of

five. With the switch in the 2 mA/mV position, a current change of two milliamperes in the conductor under test is seen as a change of one millivolt at the vertical input. In the 10 mA/mV position, a change of ten milliamperes produces one millivolt at the vertical input. The oscilloscope deflection factor may be set to any position, depending upon the amplitude of the signal. The overall deflection factor including the probe and termination may be found quickly by multiplying the slide switch position by the oscilloscope deflection factor. The following is an example:

Termination switch setting	10 mA/mV
Volts/div switch setting	20 mV/div
$\frac{10 \text{ mA}}{\text{mV}} \times \frac{20 \text{ mV}}{\text{div}} = \frac{200 \text{ mA}}{\text{div}}$	

### Probe Slider

The thumb-controlled probe slider opens the transformer core located in the end of the probe and closes it around the conductor under test. The conductor under test becomes the primary of the transformer when the core is closed. When measurements are being made, the slider should always be pushed all the way forward, as this applies pressure to the movable portion of the transformer core, assuring complete contact to the stationary portion of the transformer core.

## GENERAL OPERATING INFORMATION

### Ground Clip Leads

Ground clip leads are furnished with the probe to ground the shield around the probe transformer at the probe end of the cable when desired. When observing high frequency waveforms, use the short ground clip lead to avoid ringing.

### Direction of Current Flow

Direction of conventional current flow, as opposed to electron flow, is plus to minus. Conventional current flowing in the direction of the arrow on the probe produces a positive deflection of the waveform on the CRT (see Fig. 2-2).

### Loading Effect

To minimize loading effect of critical circuits, clamp the probe at the low or ground end of a component lead whenever possible. Also, less noise or spurious signal interference will be seen when the probe is connected near ground.

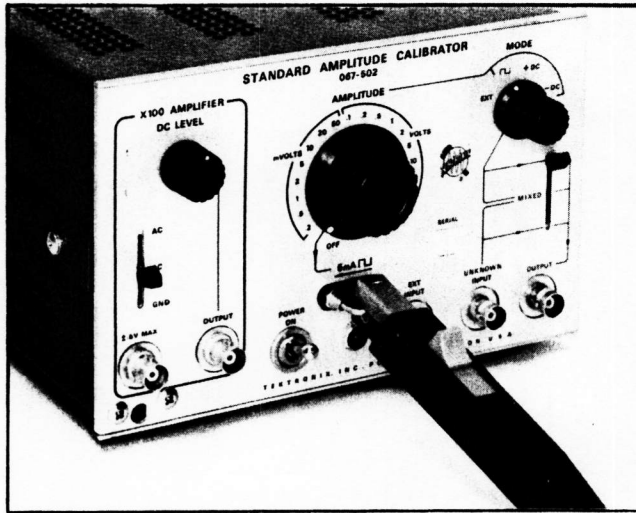

Fig. 2-2. Current flow in a conductor.

### High Currents

When measuring high currents, do not leave the current probe clamped around the conductor while disconnecting the probe cable from the termination. With the probe cable unterminated in this condition, a high voltage is developed in the secondary winding which may damage the current probe transformer.

### Increasing the Sensitivity

The current sensitivity of the P6021 Current Probe and Termination can be increased by increasing the number of turns passing through the core of the probe. For example, if the conductor is looped through the probe two times, a two-turn primary winding is formed, increasing the secondary current by a factor of two. (The ratio of current in a transformer is inversely proportional to the turns ratio.) With the P6021 Termination switch set to 2 mA/mV and the oscilloscope vertical deflection factor set to 10 mV/div, the deflection factor is actually reduced by a factor of two to 10 mA/div.

Remember, however, that the impedance reflected into the primary (circuit being measured) from the secondary (probe winding) varies as the square of the primary turns. When observing high-frequency current waveforms or fast-rise pulses, the inductance added to the primary circuit by the additional turns may be significant.

### Insertion Impedance

The insertion impedance of the current probe is the equivalent circuit which is placed in the circuit under test when

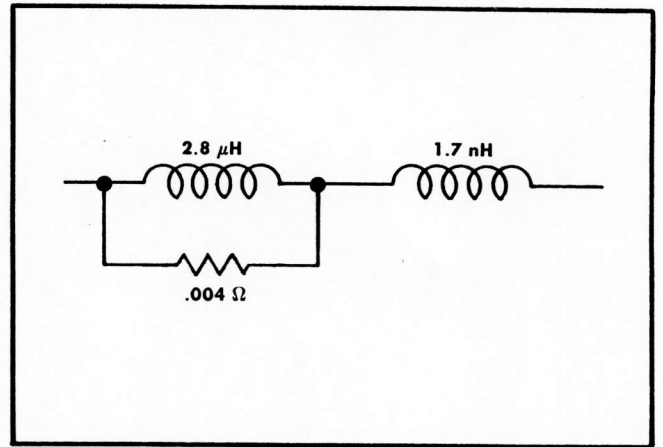

Fig. 2-3. Insertion impedance of the P6021 Current Probe.

the probe is clamped around a conductor. When observing fast-rise signals, this should be taken into consideration. Fig. 2-3 illustrates the approximate insertion impedance of the P6021 Current Probe.

### Probe Shielding

The current probe is shielded to minimize the effect of external magnetic fields. However, strong fields may interfere with a current signal being measured. If you suspect that an external field is interfering with your measurement, remove the probe from the conductor and place it in the vicinity of the original measurement. If you obtain appreciable deflection, attempt to measure the conductor current at another point, away from the magnetic field source.

If current measurements must be made in the presence of a strong external field, the external field interference may be minimized by the use of two current probes and a differential-input oscilloscope. Both current probes must be connected to the oscilloscope inputs in the same manner, using P6021 Termination.

With both probes connected to a differential-input oscilloscope, clamp one probe around the conductor in which the current is to be measured, and place the other probe near the first, with the slider closed. By setting the oscilloscope controls for common-mode rejection, the undesirable current signal induced in one probe can be minimized by the induced current in a second probe. Adjust the positions of the probes for best results. Complete cancellation of the undesirable signal may be difficult to obtain due to probe and termination differences.

## WARNING

THE FOLLOWING SERVICING INSTRUCTIONS ARE FOR USE BY QUALIFIED PERSONNEL ONLY. TO AVOID PERSONAL INJURY, DO NOT PERFORM ANY SERVICING OTHER THAN THAT CONTAINED IN OPERATING INSTRUCTIONS UNLESS YOU ARE QUALIFIED TO DO SO.

# SECTION 3 CIRCUIT DESCRIPTION

### Introduction

This section of the manual contains descriptions of the circuitry in the P6021 Current Probe and Termination. Complete circuit schematics are given in the Diagrams section. Refer to these diagrams throughout the following circuit description.

### Current Probe

The P6021 Current Probe consists of a current transformer mounted in the nose of the case, an impedance matching network, and a switch to disconnect the transformer shield from ground.

The transformer contains a two-section U-shaped ferrite core. One section is stationary, the other is mechanically movable to permit closing the core around the conductor being measured. The conductor under test forms a one-turn primary winding for the transformer; the windings around the stationary portion of the core form the secondary windings. Paralled windings in the secondary assure a fast step response. The circuitry between the transformer and the coaxial cable corrects any difference in level between the pulses induced in the paralled windings of the secondary, and matches the balanced probe winding to the cable.

As indicated on the probe body, the turns ratio of the P6021 Current Probe is 125:1. This refers to the number of windings in the secondary of the probe transformer. The two turns ratios manufactured by Tektronix, Inc. are 50:1 and 125:1. Due to the comparatively high inductance in the secondary of the 125:1 probe, the P6021 operates at a lower frequency range than the 50:1 probe.

The probe transformer is shielded to eliminate interference from outside signals. To eliminate the possibility of shorting this shield to the conductor being measured when connecting or removing the probe, slide switch SW20 disconnects the ground from the shield when the slide portion of the probe is open.

### Termination

The P6021 Termination consists of a 62.5-ohm impedance matching network to terminate the coaxial cable, and a voltage divider which is switched in by a slide switch, changing the sensitivity by a factor of five. With the slide switch in the 2 mA/mV position, a ten milliampere current signal in the conductor under test induces a five millivolt signal at the output of the termination, when the termination is connected to a one-megohm input oscilloscope. In the 10 mA/mV position, the signal is attenuated to produce a one millivolt signal at the output.

# SECTION 4

## MAINTENANCE

### Introduction

The information in this section is intended to help in removing and replacing parts in the P6021 Current Probe and Termination. When parts are replaced in either the probe or termination, it will be necessary to check the performance to determine if recalibration is needed. Refer to Section 5 for test equipment required to check the operation of the probe and termination.

### Cleaning the Current Probe

The current probe should be taken apart and cleaned periodically, depending upon the local conditions. Use a soft bristle brush to dislodge the dust and wipe clean with a soft cloth. If a persistent coating of dirt remains, it can be removed by washing the plastic portions of the probe in warm water with some liquid detergent added. Allow the parts to air dry thoroughly, or wipe dry with a lint-free cloth. Apply a coating of Lubriplate or similar lubricant to the contact areas of the spring.

While cleaning the probe, make a visual check of the probe parts. Look for any excessive wear of the slide parts which might cause improper operation later on. Dirty or worn mating surfaces between the transformer and the lid will degrade low-frequency response. Clean these surfaces if necessary.

#### NOTE

*Do not use any organic solvents to clean the probe.*

### Probe Disassembly

1. Hold the probe in a horizontal position with the slider up.
2. Move the strain relief boot back over the cable.
3. Carefully lift the upper half of the probe body slightly at the cable end and remove from the assembly.
4. Remove the small metal ball from the detent in the slider.
5. Lift the back of the return spring retainer out of the holder.
6. Remove the slider, spring retainer, and the top of the transformer as a unit. Note the position of the movable portion of the transformer in the slider.
7. Remove the two Phillips-head screws which secure the spring retainer holder to the probe body. Remove the holder.

8. Lift the circuit board, transformer, and cable out of the probe body as a unit. The transformer may be unplugged from the circuit board. The P6021 Current Probe is shown disassembled in the Mechanical Parts List section.

9. Reassemble the probe, reversing the above procedure.

### Repairing the Current Probe

To make repairs inside the body, take the probe apart as described previously. When soldering on the circuit board, observe normal circuit board techniques, using a minimum of heat. When replacing the current transformer, replace the entire assembly, including the core mounted in the slide. The transformer assembly is matched at the factory before shipment.

### Repairing the Termination

#### Replacement of Connectors

1. Remove the plastic snap-on cover from the front of the termination. This can be done with the fingers, or by inserting a small screwdriver between the cover and the termination near the part number, and turning slightly.
2. Using a heat sink, unsolder the lead(s) from the defective connector.
3. Unscrew the defective connector and remove it.
4. Replace the connector by reversing the above procedure. When replacing the front cover, align the switch with the slider in the front cover.

#### Removal of Circuit Board

1. Remove the plastic snap-on covers from the front and back of the termination.
2. Using a heat sink, unsolder the leads from the connectors.
3. Remove the two screws from the back of the circuit board.
4. Remove the circuit board from the termination. When soldering on the circuit board, observe normal circuit board techniques, using a minimum of heat.
5. Replace the circuit board by reversing the above procedure. When replacing the front cover, align the switch with the slider in the front cover.

# SECTION 5

## PERFORMANCE CHECK/CALIBRATION

### Introduction

This section provides procedures to be used in checking the performance or in calibrating the P6021 Current Probe and Termination. Limits and tolerances in this section are given as calibration guides and are not necessarily instrument specifications.

To ensure measurement accuracy, check the performance of the probe and termination whenever they are changed from one test oscilloscope to another, especially when changing input capacitance, and recalibrate if necessary. Check the calibration of the probe and termination every 1000 hours of operation, or every six months if used infrequently. Before calibration thoroughly clean and inspect the probe as outlined in the Maintenance section. Dirty or worn mating surfaces between the transformer and the lid will degrade low-frequency response. Clean these surfaces if necessary.

The features provided by this section are:

**Index.** The Short-Form Procedure lists the step numbers and titles of the complete Performance Check/Calibration Procedure and gives the page on which each step begins. Therefore, the Short-Form Procedure can be used as an index to the steps in the complete procedure.

**Calibration Record.** The Short-Form Procedure can be reproduced and used as a permanent record of instrument calibration. Spaces are provided to record performance data for this instrument or to check off steps as they are completed.

**Abridged Calibration Procedure.** The Short-Form Procedure lists the adjustments necessary for each step and/or the applicable tolerance for correct calibration. The experienced calibrator who is familiar with the calibration of this instrument can use this procedure to facilitate checking or calibrating this instrument.

**Performance Check.** The Calibration Procedure can be used as a performance checkout procedure by completing all portions except the ADJUST— part of a step. This checks the probe and termination cover or making internal adjustments.

**Complete Calibration.** Completion of each step in the Calibration Procedure checks the probe and termination to the original performance standards and gives the procedure to set each adjustment to its optimum setting. Where possible, instrument performance is checked before an adjustment is made. For best overall instrument performance, make each adjustment to the exact setting even if the CHECK— is within the allowable tolerance.

## EQUIPMENT REQUIRED

### General

The following items are required for calibration of the P6021 Current Probe and Termination. Specifications given are the minimum necessary for accurate calibration. All test equipment is assumed to be correctly calibrated and operating within the given

specifications. If equipment is substituted, it must meet or exceed the specifications of the recommended equipment.

For the quickest and most accurate calibration, special Tektronix calibration fixtures are used where necessary. These special calibration fixtures are available from Tektronix, Inc. Order by part number through your local Tektronix Field Office or representative.

### Test Equipment

1. Test oscilloscope. Bandwidth, DC to 75 megahertz; deflection factor, .01 V/cm and .02 V/cm. Tektronix 580-series recommended.
2. Pulse generator. Risetime, 0.25 nanosecond; amplitude 0 to 50 volts into 50 ohms. Tektronix Type 109 recommended.
3. Low-frequency constant amplitude signal generator. Frequency, 120 hertz to 50 kilohertz; output amplitude, variable from 2.8 volts to 5 volts into 50 ohms; amplitude regulation accuracy, constant within 3% of reference at 50 kilohertz as output frequency changes. For example, General Radio 1310-A Oscillator.
4. Transmission line. Risetime, 0.1 nanosecond delay, 60 nanoseconds. Tektronix Type 113 Delay Cable recommended.

### Accessories

5. Cable (two). Impedance, 50 ohms, electrical length, 5 nanoseconds; connectors, GR. Tektronix Part No. 017-0502-00.
6. Attenuator (two). Impedance, 50 ohms; attenuation, 10×; connectors, GR. Tektronix Part No. 017-0078-00.
7. Attenuator. Impedance, 50 ohms; attenuation, 5×; connectors, GR. Tektronix Part No. 017-0079-00.
8. Attenuator. Impedance, 50 ohms; attenuation, 2×; connectors, GR. Tektronix Part No. 017-0080-00.
9. Termination. Impedance, 50 ohms; description, end-line; connector, GR. Tektronix Part No. 017-0081-00.
10. Termination. Impedance, 50 ohms; description, thru-line; connectors, GR to BNC male. Tektronix Part No. 017-0083-00.
11. Adapter. Description, GR to BNC male. Tektronix Part No. 017-0064-00.
12. Adapter. Description, GR to BNC female. Tektronix Part No. 017-0063-00.
13. Adapter. Description, Dual banana plug to BNC female. Tektronix Part No. 103-0090-00.



14. Insertion unit. Connectors, GR. Tektronix Part No. 017-0030-00.

15. Resistor. Description, 28  $\Omega$ , 1/2 W, 1%. Tektronix Part No. 323-0044-00.

16. Resistor. Description, 110  $\Omega$ , 1/2 W, 1%. Tektronix Part No. 323-0101-00.

17. Calibration Fixture. Description, 50-ohm terminating current loop; connector, GR. Tektronix Part No. 067-0559-00.

18. Viewing hood. Purpose, for viewing low-intensity displays on 580-series test oscilloscope. Tektronix Part No. 016-0001-01.

19. Adjustment tool. Description, non-conducting screwdriver. Tektronix Part Nos. 003-0307-00 (handle), and 003-0334-00 (insert).

SHORT-FORM PROCEDURE

Type P6021 Probe and Termination, Date Code \_\_\_\_\_

Calibration date \_\_\_\_\_

Calibrated by \_\_\_\_\_

- 1. Adjust Current Probe (C13, R10, R12)  
 REQUIREMENT: Correct adjustment (see complete procedure).  
 PERFORMANCE: Correct \_\_\_\_\_; incorrect \_\_\_\_\_

- 2. Check/Adjust Aberrations (C22, C25, R36)  
 REQUIREMENT: 5 Foot Probe—Aberrations within +3%, -3% total of 4% peak to peak during first 50 nanoseconds; +1%, -1%, total of 2% peak to peak thereafter. 9 Foot Probe—Aberrations within +4%, -4%, total of 5% peak to peak during first 50 nanoseconds, +1%, -1%, total of 2% peak to peak thereafter.
- 3. Check Risetime  
 REQUIREMENT: 10 mA/mV risetime of  $\leq 6.5$  nanoseconds; 2 mA/mV risetime of  $\leq 6.7$  nanoseconds.  
 PERFORMANCE: Correct \_\_\_\_\_; incorrect (list exceptions) \_\_\_\_\_
- 4. Check Sensitivity  
 REQUIREMENT: 2 mA/mV sensitivity of 80 millivolts,  $\pm 3\%$ , at test oscilloscope input with 8-volt pulse applied to Calibration Fixture; 10 mA/mV sensitivity of 80 millivolts,  $\pm 3\%$ , at test oscilloscope input with 40-volt pulse applied to Calibration Fixture.  
 PERFORMANCE: Correct \_\_\_\_\_; incorrect (list exceptions) \_\_\_\_\_
- 5. Check Low Frequency Response  
 REQUIREMENT: 2 mA/mV low frequency response of  $\leq 450$  hertz; 10 mA/mV low frequency response of  $\leq 120$  hertz.  
 PERFORMANCE: Correct \_\_\_\_\_; incorrect (list exceptions) \_\_\_\_\_

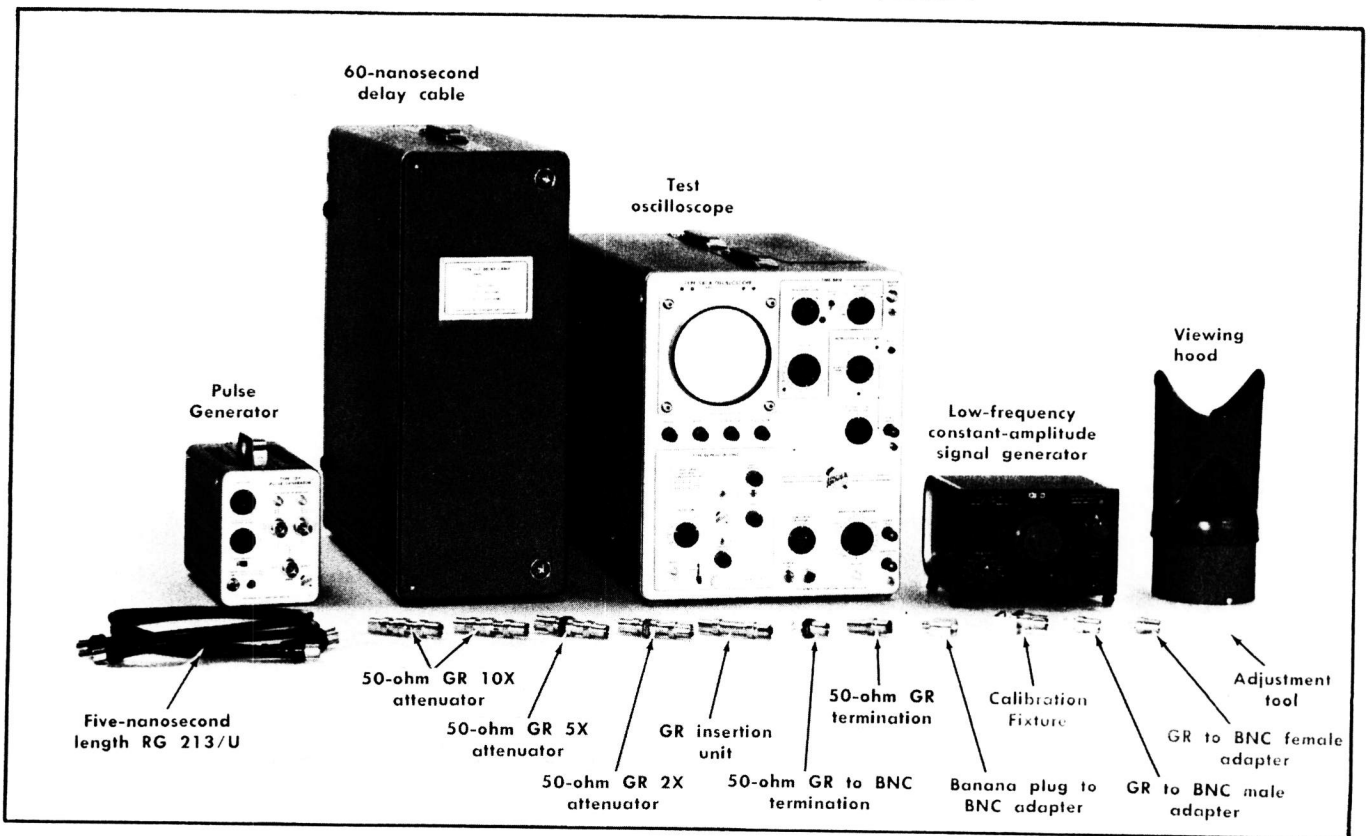

Fig. 5-1. Equipment required for calibration.

**Performance Check/Calibration—P6021**

**PERFORMANCE CHECK/CALIBRATION PROCEDURE**

**General**

The following procedure is arranged so that the P6021 Current Probe and Termination can be calibrated with the least interaction of adjustments and reconnection of equipment. The equipment required for the entire procedure is shown in Fig. 5-1. Following the picture is a complete list of control settings for the test equipment.

All waveforms shown in this procedure were taken with a Tektronix Oscilloscope Camera System. The following procedure uses the equipment listed under Test Equipment Required. If equipment is substituted, control settings or equipment setup may need to be altered to meet the requirements of the equipment used. Detailed operating instructions for the test equipment is not given in this procedure. If in doubt as to the correct operation of any of the test equipment, refer to the instruction manual for that unit.

**Preliminary Procedure for Complete Calibration**

To eliminate interaction of current probe and termination adjustments when performing calibration, the probe is adjusted using a standard 50-ohm termination. However, a special impedance matching network must be constructed to match the 62.5-ohm probe cable to the 50-ohm termination. Using a GR insertion unit, construct the network shown in Fig. 5-2. Mark the insertion unit for direction and place the cover over the openings.

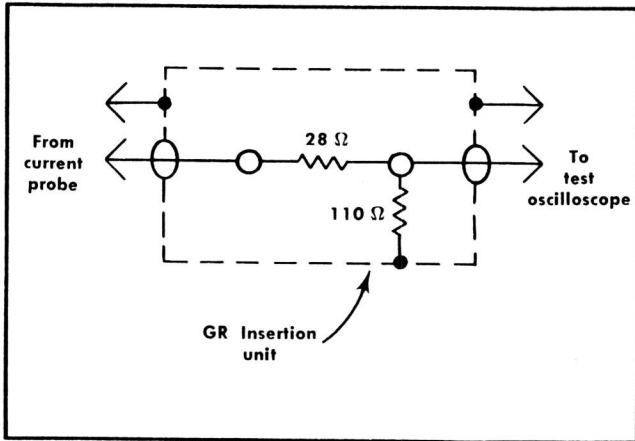

Fig. 5-2. Impedance matching network constructed in GR insertion unit.

Remove the top cover only from the P6022 Termination. The snap-on cover may be removed either with the fingers or by placing a small screwdriver between the cover and the termination, near the part number, and turning slightly. The bottom cover must remain in place whenever the termination is in use.

**TEST OSCILLOSCOPE**

Focus	Any position
Intensity	Midrange

Astigmatism	Any position
Scale Illum	As desired
Volts/Cm	.02
Variable Volts/Cm	Cal
Gain	×10
Input Coupling	DC
Trigger Slope	+
Triggering Source	Int-AC
Time/Cm	.05
Horizontal Display	Internal Sweep
5X Magnifier	Off

**PULSE GENERATOR**

Amplitude	30
Voltage Range	50
Pulse Polarity	+

**NOTE**

If completing Performance Check only, do steps 1a, 1b, and 1c. Then proceed to step 2.

**1. Adjust Current Probe**

a. Connect a 50-ohm GR termination to one of the pulse generator charge line connectors.

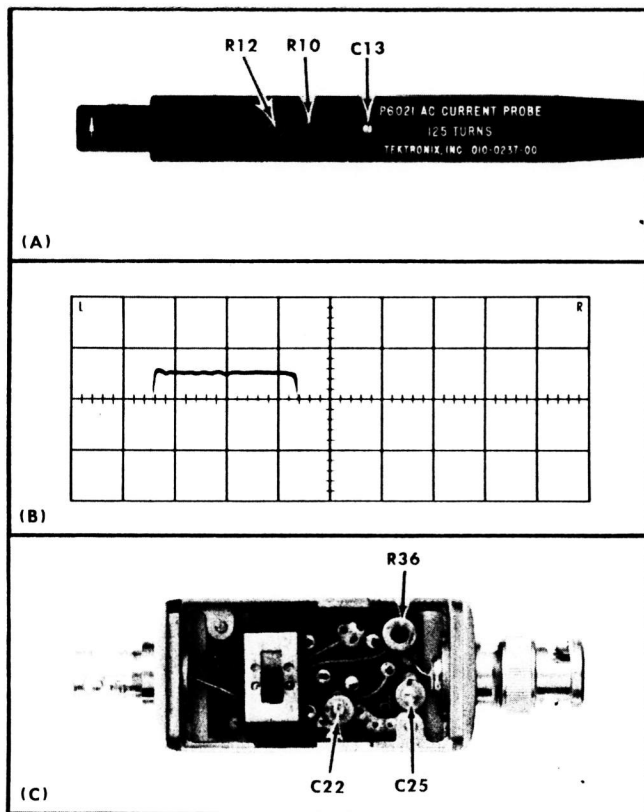

Fig. 5-3. P6021 aberrations, showing (A) location of probe adjustments, (B) four-centimeter display of pulse generator output, and (C) location of termination adjustments.

- b. Connect a five-nanosecond length of GR 213/U coaxial cable from the remaining charge line connector to one side of the 60-nanosecond delay cable.
- c. Connect the Calibration Fixture to the pulse generator output connector.
- d. To the input of the test oscilloscope, connect a 50-ohm GR to BNC termination, a 50-ohm GR 2× attenuator, the insertion unit (see Fig. 5-2 for direction), a GR to BNC female adapter, and the P6021 Current Probe. Clamp the probe around the conductor in the Calibration Fixture and move the slider all the way forward.
- e. Turn on the test equipment and adjust the triggering controls, Intensity, and pulse generator amplitude to obtain a four-centimeter display. (If necessary, use the viewing hood on the test oscilloscope.) Position the top of the display within the CRT viewing area.
- f. ADJUST—C13, R10, and R12 (see Fig. 5-3A) for minimum aberrations and best flat-top response.
- g. Remove the 50-ohm termination, 2× attenuator, insertion unit, and the GR to BNC adapter.

**2. Check/Adjust Aberrations**

- a. Connect the P6021 Termination to the input of the test oscilloscope. Set the termination slide switch to the 2 mA/mV position.
- b. Connect the P6021 Probe from the Calibration Fixture to the termination.
- c. Adjust the pulse generator output amplitude for four centimeters of deflection. Position the top of the display within the CRT viewing area.
- d. CHECK—5 Foot Probe—First 50 nanoseconds of step for aberrations within +3%, -3%, total of 4% peak to peak; +1%, -1%, total of 2% peak to peak after the first 50 nanoseconds (not including effects of the test oscilloscope). 9 Foot Probe—First 50 nanoseconds of step for aberrations within +4%, -4%, total of 5% peak to peak. +1%, -1%, total of 2% peak to peak after the first 50 nanoseconds (not including the effects of the test oscilloscope).
- e. ADJUST—C22, C25, and R36 (see Fig. 5-3C) for aberrations within +3%, -3%, total of 4% peak to peak during first 50 nanoseconds; +1%, -1%, total of 2% peak to peak after the first 50 nanoseconds (not including effects of the test oscilloscope).

f. Set the termination slide switch to the 10 mA/mV position and increase the amplitude of the pulse generator output for four centimeters of deflection. Position the top of the display within the CRT viewing area.

g. CHECK—First 50 nanoseconds of step for aberrations within +3%, -3%, total of 4% peak to peak; +1%, -1%, total of 2% peak to peak after first 50 nanoseconds (not including effects of the test oscilloscope). See Fig. 5-3B.

**3. Check Risetime**

a. Turn on the test oscilloscope 5× magnifier and position the leading edge of the display near the center of the CRT.

b. CHECK—CRT display for risetime of  $\leq 6.5$  nanoseconds (with 580-series test oscilloscope operating within specification). See Fig. 5-4A.

c. Set the termination slide switch to the 2 mA/mV position, and adjust the amplitude of the pulse generator output for four centimeters of deflection.

d. CHECK—CRT display for risetime of  $\leq 6.7$  nanoseconds (with 580-series test oscilloscope operating within specification). See Fig. 5-4B.

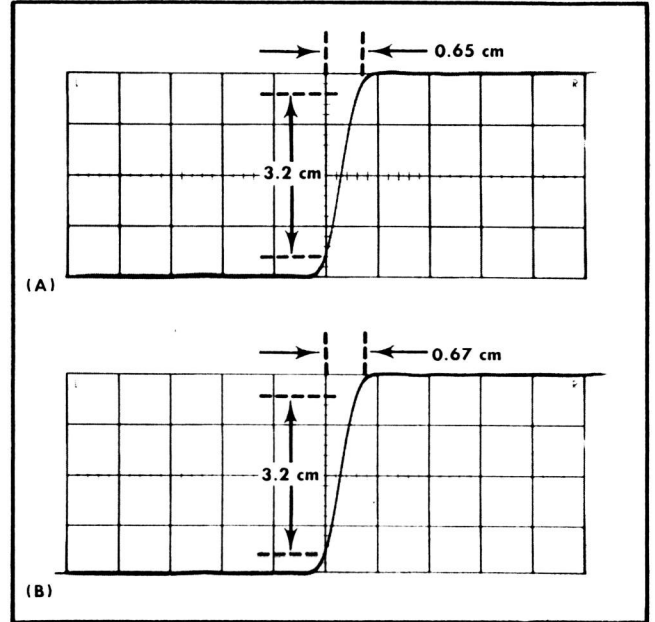

Fig. 5-4. Risetime check showing (A) within 6.5 nanoseconds at 10 mA/mV, and (B) within 6.7 nanoseconds at 2 mA/mV.

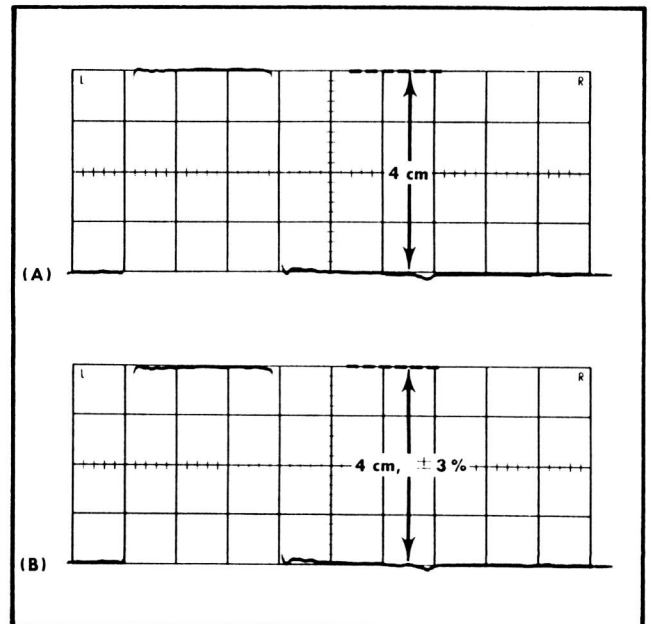

Fig. 5-5. Sensitivity check showing (A) four-division deflection from voltage source, and (B) current probe and termination deflection of four divisions,  $\pm 3\%$ .

## Performance Check/Calibration—P6021

### 4. Check Sensitivity

a. Remove the P6021 Probe, Termination, and Calibration Fixture from the test equipment.

b. Connect two 50-ohm GR 10× attenuators and a five-nanosecond length of RG 213/U cable to the output of the pulse generator.

c. Connect the other end of the cable through the 50-ohm GR to BNC termination to the input of the test oscilloscope.

d. Turn the sweep magnifier off and adjust the amplitude of the pulse generator output for four centimeters of deflection. See Fig. 5-5A.

e. Remove the attenuators, cable, and termination and replace with the P6021 Probe, Termination, and Calibration Fixture. Set the termination slide switch to the 2 mA/mV position.

f. CHECK—CRT display for four centimeters of deflection,  $\pm 3\%$  (not including GR attenuator error). See Fig. 5-5B.

g. Remove the P6021 Probe, Termination, and Calibration Fixture from the test oscilloscope.

h. Connect two 50-ohm GR 10× attenuators, one 50-ohm GR 5× attenuator, and a five-nanosecond length of RG 213/U cable to the output of the pulse generator.

i. Connect the other end of the cable through the 50-ohm GR to BNC termination to the input of the test oscilloscope.

j. Adjust the amplitude of the pulse generator output for four centimeters of deflection. See Fig. 5-5A.

k. Remove the attenuators, cable, and termination and replace with the P6021 Probe, Termination, and Calibration Fixture. Set the termination slide switch to the 10 mA/mV position.

l. CHECK—CRT display for four centimeters of deflection,  $\pm 3\%$  (not including GR attenuator error). See Fig. 5-5B.

### 5. Check Low Frequency Response

a. Connect the banana plug to BNC adapter, the BNC male to GR adapter, and the Calibration Fixture to the output of the low-frequency signal generator. Connect the P6021 Probe to the Calibration Fixture.

b. Set the test oscilloscope Time/Cm switch to 2 ms and the termination slide switch to the 2 mA/mV position.

c. Set the signal generator frequency to 50 kHz and adjust the output level for 1.4 centimeters of vertical deflection. See Fig. 5-6A.

d. Lower the frequency of the signal generator until the amplitude of the display reduces to one centimeter. See Fig. 5-6B.

e. CHECK—Signal generator frequency setting of  $\leq 450$  hertz.

f. Set the test oscilloscope Volts/Cm to .01 V, Time/Cm to 5 ms, and the termination slide switch to the 10 mA/mV position.

g. Set the signal generator frequency to 50 kHz and adjust the output level for one centimeter of vertical deflection. See Fig. 5-7A.

h. Lower the frequency of the signal generator until the amplitude of the display reduces to 0.7 centimeter. See Fig. 5-7B.

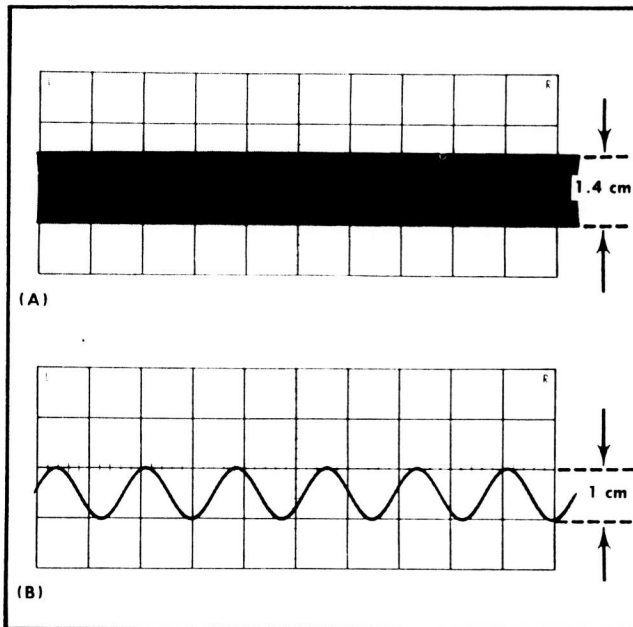

Fig. 5-6. Low-frequency response check, 2 mA/mV, showing (A) 1.4-centimeter, 50 kHz display, and (B) one-centimeter display.

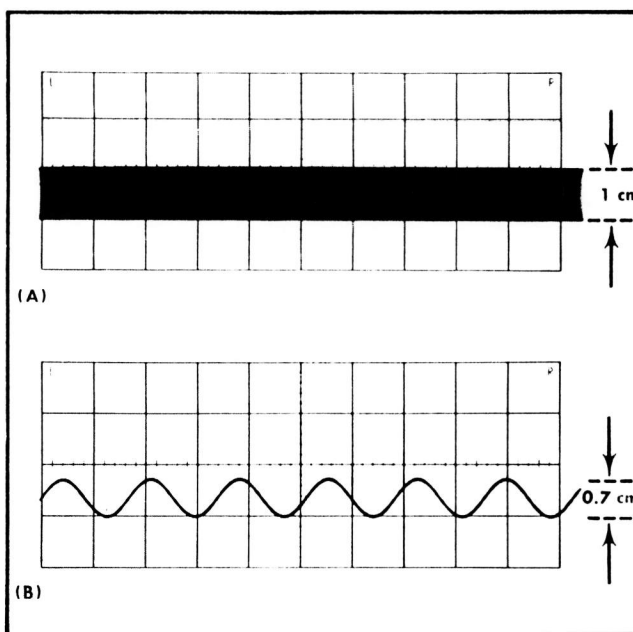

Fig. 5-7. Low-frequency response check, 10 mA/mV, showing (A) one-centimeter, 50 kHz display, and (B) 0.7-centimeter display.

i. CHECK—Signal generator frequency setting of  $\leq 120$  hertz.

#### NOTE

*Dirty or worn mating surfaces between the transformer and the lid will degrade low-frequency response. Clean if necessary. Refer to "Maintenance" (Section 4).*

j. Disconnect all test equipment and replace the termination cover.

## SECTION 6

# ELECTRICAL PARTS LIST

Values are fixed unless marked Variable.

### P6021 PROBE

Ckt. No.	Tektronix Part No.	Serial/Model No. Eff	No. Disc	Description
----------	--------------------	----------------------	----------	-------------

#### Capacitors

Tolerance  $\pm 20\%$  unless otherwise indicated.

C13	281-0122-00		2.5-9 pF, Var			
C14	283-0182-00		51 pF	Cer	400 V	5%

#### Inductors

L10	*108-0526-00		50 $\mu$ H			
L12	*108-0526-00		50 $\mu$ H			
L14	*108-0529-00		1.6 $\mu$ H			

#### Resistors

Resistors are fixed, composition,  $\pm 10\%$  unless otherwise indicated.

R10	311-0635-00		1 k $\Omega$ , Var			
R12	311-0635-00		1 k $\Omega$ , Var			
R13	317-0821-00		820 $\Omega$	$\frac{1}{8}$ W		5%
R14	317-0121-00		120 $\Omega$	$\frac{1}{8}$ W		5%

#### Transformers

T1	*120-0614-00		Current			
T14	*120-0468-00		Toroid, 6 turns bifilar			

Electrical Parts List—P6021

P6021 TERMINATION

Ckt. No.	Tektronix Part No.	Serial/Model No. Eff	Disc	Description
----------	--------------------	----------------------	------	-------------

**Capacitors**

Tolerance  $\pm 20\%$  unless otherwise indicated.

C22	281-0123-00			5-25 pF, Var
C25	281-0123-00			5-25 pF, Var
C30	283-0140-00			4.7 pF
				Cer 50 V 5%

**Connectors**

J20	131-0602-00			Receptacle, electrical, male
P39	131-0106-02			Receptacle, electrical, female

**Inductors**

L22	*108-0525-00			140 $\mu$ H
L31	*108-0395-00			64 $\mu$ H

**Resistors**

Resistors are fixed, composition,  $\pm 10\%$  unless otherwise indicated.

R22	317-0101-00			100 $\Omega$	$\frac{1}{8}$ W		5%
R24	321-0077-00			61.9 $\Omega$	$\frac{1}{8}$ W	Prec	1%
R31	321-0069-00			51.1 $\Omega$	$\frac{1}{8}$ W	Prec	1%
R33	321-0039-00			24.9 $\Omega$	$\frac{1}{8}$ W	Prec	1%
R34	321-0038-00			24.3 $\Omega$	$\frac{1}{8}$ W	Prec	1%
R35	317-0036-00			3.6 $\Omega$	$\frac{1}{8}$ W		5%
R36	311-0605-00			200 $\Omega$ , Var			

**Switch**

SW30	260-0723-00			Slide
------	-------------	--	--	-------

## SECTION 7 MECHANICAL PARTS LIST

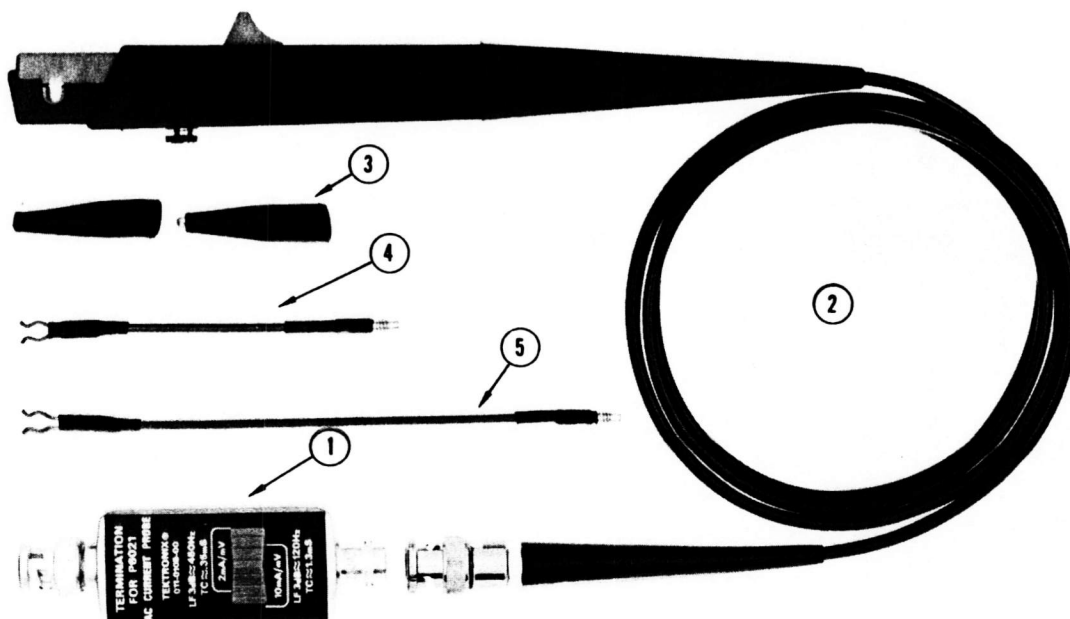

**PROBE PACKAGE**

Fig. & Index No.	Tektronix Part No.	Serial/Model Eff	No. Disc	Q † y	Description					
					1	2	3	4	5	
	015-0140-00		6948	1						PROBE PACKAGE, w/termination
	015-0140-02	6949		1						PROBE PACKAGE, w/termination
	015-0140-03			1						PROBE PACKAGE, w/termination (9 foot probe)
	-			-						probe package includes:
1	011-0105-00			1						TERMINATION, coaxial
	010-0237-00		6948	1						PROBE PACKAGE, w/accessories
	010-0237-02	6949		1						PROBE PACKAGE, w/accessories
	010-0244-02			1						PROBE PACKAGE, w/accessories (9 foot probe)
	-			-						probe package includes:
2	010-0237-01		6948	1						PROBE, P6021
	010-0237-03	6949		1						PROBE, P6021
	010-0244-02			1						PROBE, P6201 (9 foot)
3	344-0046-00			2						CLIP, probe
4	175-0263-00			1						CABLE ground lead, 3 inch
5	175-0124-00			1						CABLE ground lead, 5 inch

Mechanical Parts List—P6021

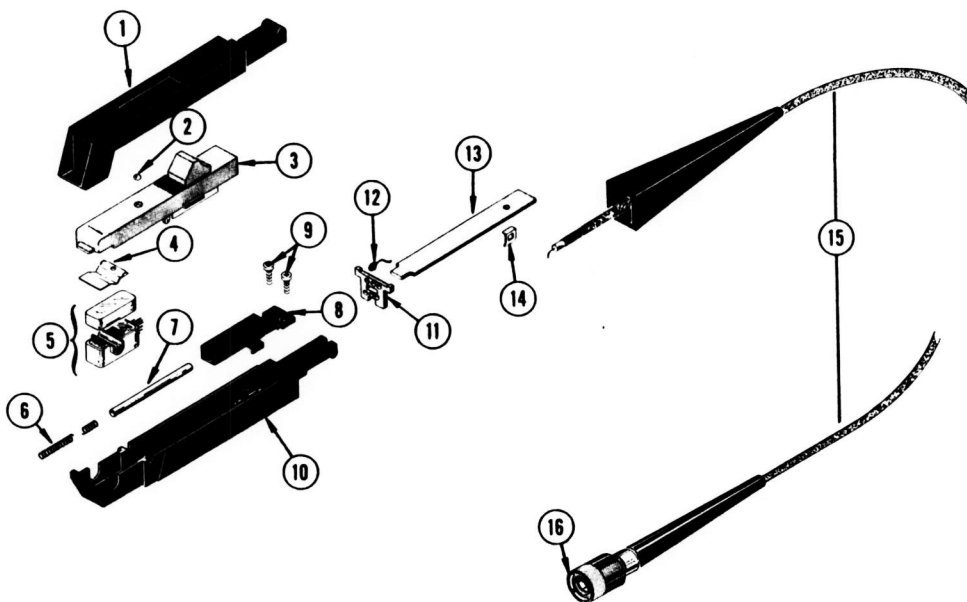

P6021 PROBE

®

Fig. & Index No.	Tektronix Part No.	Serial/Model No.		Q	Description
		Eff	Disc		
				†	
				Y	1 2 3 4 5
	010-0237-01		6948	1	PROBE, P6021
	010-0237-03	6949		1	PROBE, P6021
	010-0244-03			1	PROBE, P6021 (9 foot)
	- - - - -			-	probe includes:
1	204-0367-00			1	BODY, probe, top
2	214-0997-00			1	BALL, metal, 0.094 inch OD
3	351-0191-00			1	SLIDE ASSEMBLY, upper shell
4	131-0715-00			1	CONTACT, electrical
5	- - - - -			1	T1 TRANSFORMER
6	214-0835-00			1	SPRING, helical, compression
7	214-0849-00			1	RETAINER, return spring
8	352-0159-00			1	HOLDER, spring return
9	211-0001-00			2	SCREW, 2-56 x 1/4 inch, RHS
10	204-0368-00		6948	1	BODY, probe, bottom
	204-0368-02	6949		1	BODY, probe, bottom
	204-0368-03			1	BODY, probe, bottom (9 foot probe)
11	352-0158-00			1	HOLDER, circuit board
12	136-0252-00			6	SOCKET, pin connector
13	670-1117-00			1	ASSEMBLY, circuit board
	- - - - -			-	assembly includes:
14	131-0710-00			1	CONTACT, electrical, circuit board to ground
	388-1209-00			1	BOARD, circuit
15	175-1041-00		6948	1	CABLE ASSEMBLY, RF
	175-1041-01	6949		1	CABLE ASSEMBLY, RF
	175-1060-01			1	CABLE ASSEMBLY, RF (9 foot probe)
	- - - - -			-	cable assembly includes:
	134-0044-00		6948	1	PLUG, probe, BNC
	214-0109-00		6948	1	CONTACT, pin, probe
	358-0072-00		6948	1	BUSHING, insulator, 0.323 inch long
	361-0022-00		6948	1	SPACER, plastic, 23/64 inch long
16	131-0750-00	6049		1	CONNECTOR, plug, BNC
	070-0947-00			1	MANUAL, instruction (not shown)



Mechanical Parts List—P6021

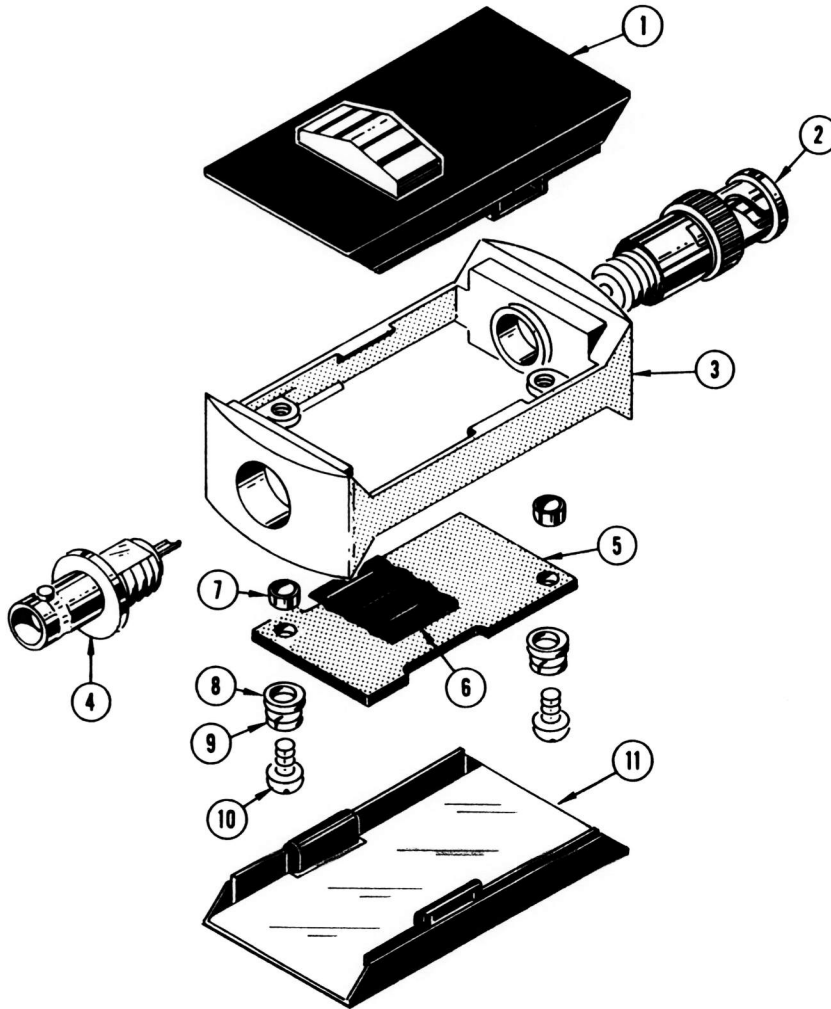

P6021 TERMINATION

Fig. & Index No.	Tektronix Part No.	Serial/Model No. Eff	No. Disc	Q					Description	
				†	y	1	2	3		4
	011-0105-00			1						TERMINATION, P6021
				-						termination includes:
1	200-0852-08			1						COVER, termination, top, w/knob
2	131-0602-00			1						CONNECTOR, electrical, BNC, male
3	426-0423-03			1						FRAME, termination
4	131-0106-02			1						CONNECTOR, BNC, female
5	670-1052-00			1						ASSEMBLY, circuit board
				-						assembly includes:
6	214-1108-00			1						INSULATOR, plate
	388-1212-00			1						BOARD, circuit
				-						mounting hardware: (not included w/assembly)
7	361-0219-00			2						SPACER, sleeve, 0.087 ID x 0.187 inch OD
8	210-1008-00			2						WASHER, flat, 0.090 ID x 0.188 inch OD
9	210-0053-00			2						LOCKWASHER, split, #2
10	211-0001-00			2						SCREW, 2-56 x 1/4 inch, RHS
11	200-0851-03			1						COVER, termination, bottom

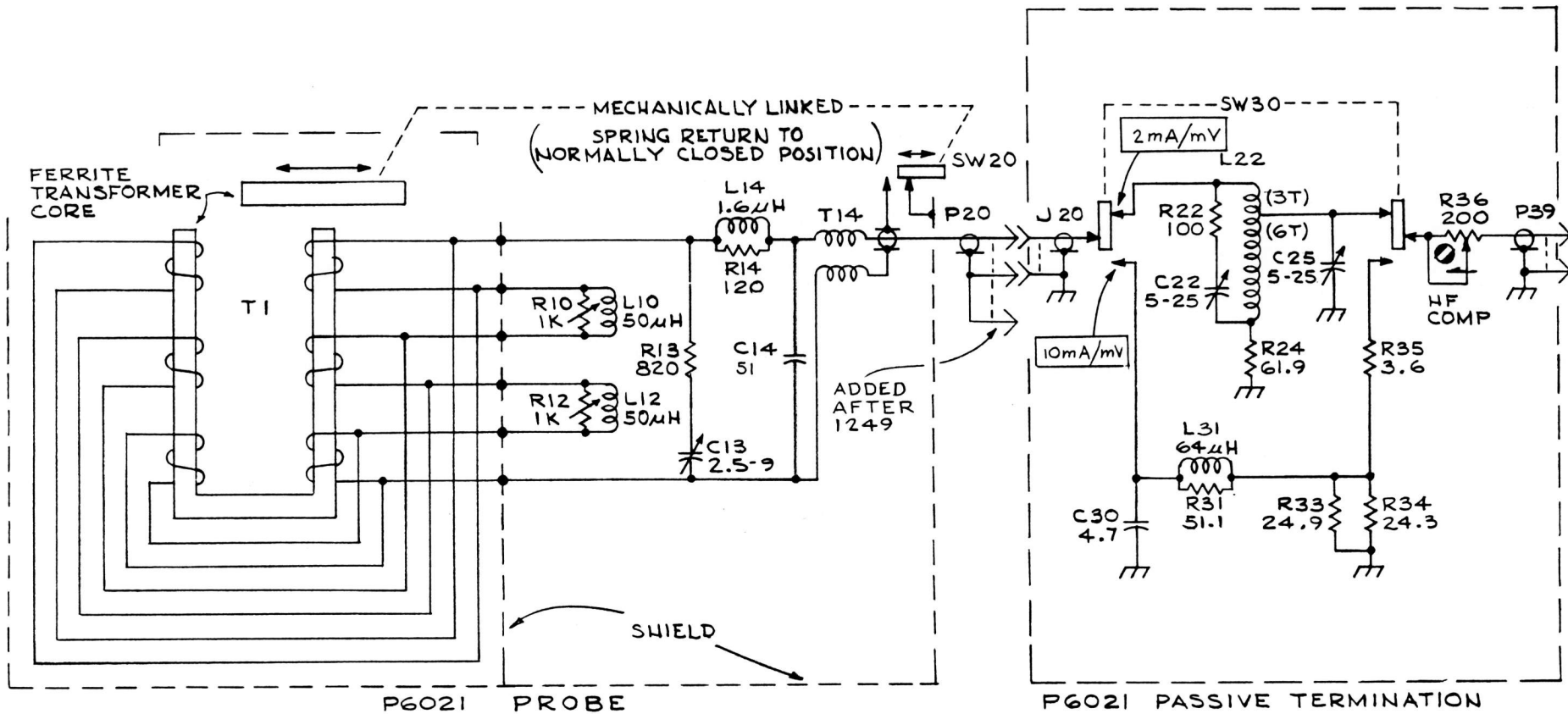

Ⓟ

REV. APR 1974

TYPE P6021 CURRENT PROBE & TERMINATION 0670

# Tektronix MANUAL CHANGE INFORMATION

COMMITTED TO EXCELLENCE

Date: 8-13-86

Change Reference: C2/0886

Product: P6021 Current Probe and Termination

Manual Part No.: 070-0947-00

DESCRIPTION

PG 60

## SPECIFICATION CHANGE

Replace the specification for "Maximum CW Current" on page 1-1, with the following:

Characteristic	Performance Requirement
Maximum p-p CW Current at 2 mA/mV	5 A between 1.2 kHz and 5 MHz.
Maximum p-p CW Current at 10 mA/mV	15 A between 300 Hz and 5 MHz.

Add Fig. 1-2:

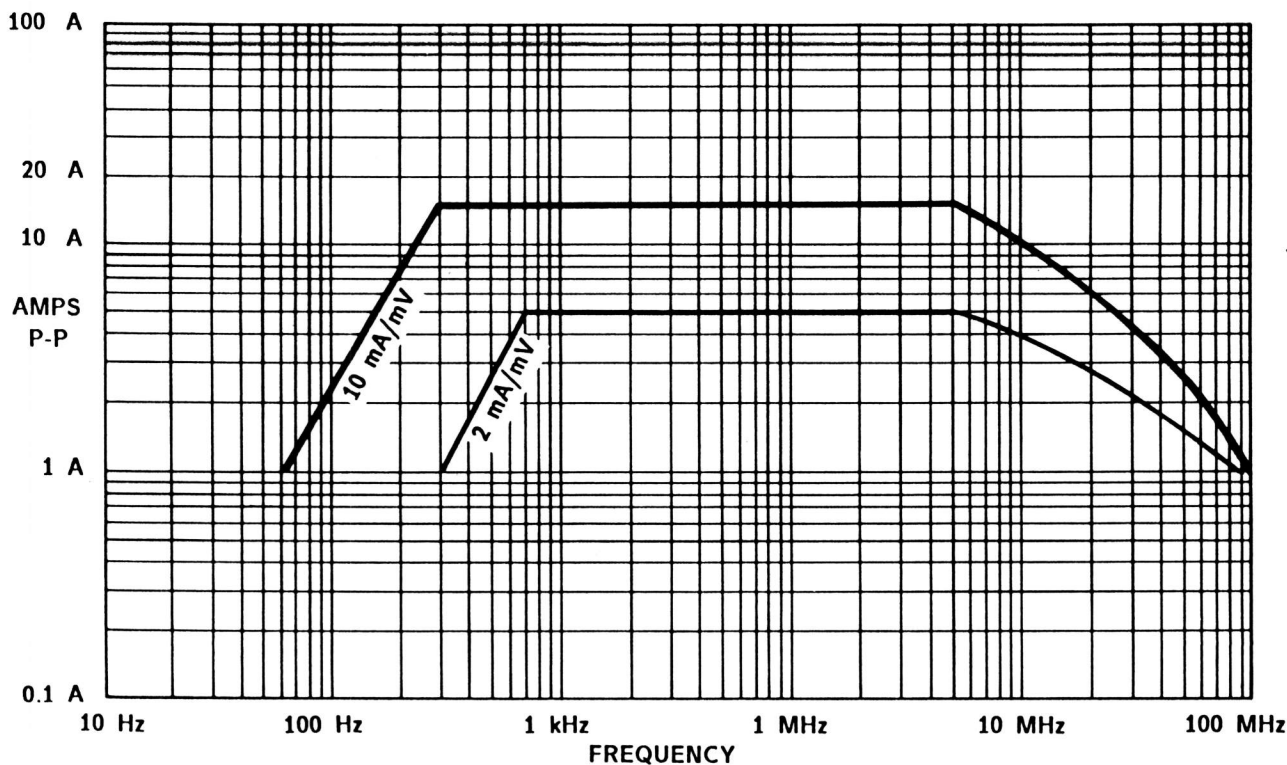

Fig. 1-2. P6021/Termination Input Current vs Frequency Derating.